

## Electronic device circuit breaker - EC-E1 1A - 0903023

Please be informed that the data shown in this PDF Document is generated from our Online Catalog. Please find the complete data in the user's documentation. Our General Terms of Use for Downloads are valid (<http://phoenixcontact.com/download>)



Electronic circuit breaker, signal contact: 1 N/O contact, nominal current: 1 A

### Your advantages

- A combination of active electronic current limitation in the event of short circuit and overload shutdown ensures that the circuit breaker can respond to overloads faster than the switched-mode power supply unit
- Selective protection of all 24 V DC load circuits at switched-mode power supply units
- The residual current is always limited to 1.3 - 1.8 times the nominal current

### Key Commercial Data

Packing unit	1 pc
GTIN	
GTIN	4046356327992
Weight per Piece (excluding packing)	66.670 g
Custom tariff number	85362010
Country of origin	Germany

### Technical data

#### General

Installation instructions	When mounted in rows without convection cooling, the nominal device current should only be led to a maximum of 80% due to the thermal effect during continuous operation (100% operating factor). Special precautionary measures must be taken in systems or machines, to prevent components from restarting (e.g., use of a safety PLC). Parallel connection of multiple circuit breakers is not permitted.
Mounting type	DIN rail: 35 mm
Color	black

# Electronic device circuit breaker - EC-E1 1A - 0903023

## Technical data

### General

Number of positions	1
Flammability rating according to UL 94	V0

### Electrical data

Fuse	electronic
Fuse type	Automatic device
Rated surge voltage	0.5 kV
Operating voltage	24 V DC
	18 V DC ... 32 V DC
Nominal current $I_N$	1 A
Required backup fuse	not required, integrated failsafe element
Dielectric strength	max. 32 V DC (Load circuit)
Degree of pollution	2
Switching capacity $I_{CN}$	Active current limitation
Closed-circuit current range $I_O$	typ. 25 mA $\pm$ 5 mA (When switched on)

### Dimensions

Height	83 mm
Width	12.5 mm
Depth	80 mm
Height NS 35/7,5	83 mm
Height NS 35/15	90.5 mm

### Ambient conditions

Degree of protection	IP20 (Housing)
Ambient temperature (operation)	0 °C ... 50 °C (non-condensing)

### Connection data

Conductor cross section solid min.	0.5 mm <sup>2</sup>
Conductor cross section solid max.	16 mm <sup>2</sup>
Conductor cross section flexible min.	0.5 mm <sup>2</sup>
Conductor cross section flexible max.	16 mm <sup>2</sup>
Conductor cross section AWG min.	20
Conductor cross section AWG max.	6
Conductor cross section flexible, with ferrule without plastic sleeve min.	0.5 mm <sup>2</sup>
Conductor cross section flexible, with ferrule without plastic sleeve max.	10 mm <sup>2</sup>
Conductor cross section flexible, with ferrule with plastic sleeve min.	0.5 mm <sup>2</sup>
Conductor cross section flexible, with ferrule with plastic sleeve max.	10 mm <sup>2</sup>
2 conductors with same cross section, solid min.	0.5 mm <sup>2</sup>

## Electronic device circuit breaker - EC-E1 1A - 0903023

### Technical data

#### Connection data

2 conductors with same cross section, solid max.	4 mm <sup>2</sup>
2 conductors with same cross section, stranded min.	0.5 mm <sup>2</sup>
2 conductors with same cross section, stranded max.	4 mm <sup>2</sup>
2 conductors with same cross section, stranded, ferrules without plastic sleeve, min.	0.5 mm <sup>2</sup>
2 conductors with same cross section, stranded, ferrules without plastic sleeve, max.	2.5 mm <sup>2</sup>
2 conductors with same cross section, stranded, TWIN ferrules with plastic sleeve, min.	0.5 mm <sup>2</sup>
2 conductors with same cross section, stranded, TWIN ferrules with plastic sleeve, max.	6 mm <sup>2</sup>
Connection method	Screw connection
Stripping length	10 mm
Screw thread	M4
Tightening torque max	1.2 Nm

#### Standards and Regulations

Standards/specifications	UL 508
	CSA 22.2 No. 14
	UL 2367
	CSA 22.2 No. 142
	CSA 22.2 No. 213
	UL 1604

#### Environmental Product Compliance

REACH SVHC	Lead 7439-92-1
China RoHS	Environmentally Friendly Use Period = 50
	For details about hazardous substances go to tab "Downloads", Category "Manufacturer's declaration"

### Drawings

# Electronic device circuit breaker - EC-E1 1A - 0903023

Diagram

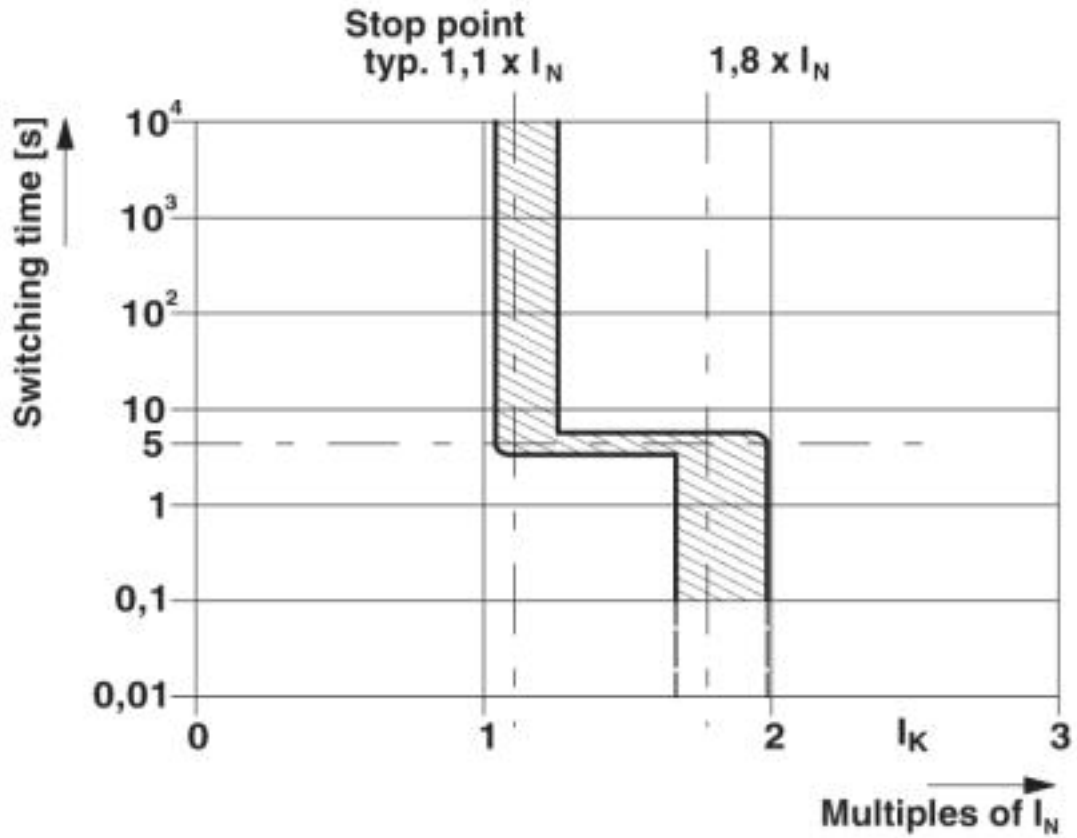

Trigger characteristic

# Electronic device circuit breaker - EC-E1 1A - 0903023

Circuit diagram

## EC-E 1 ...

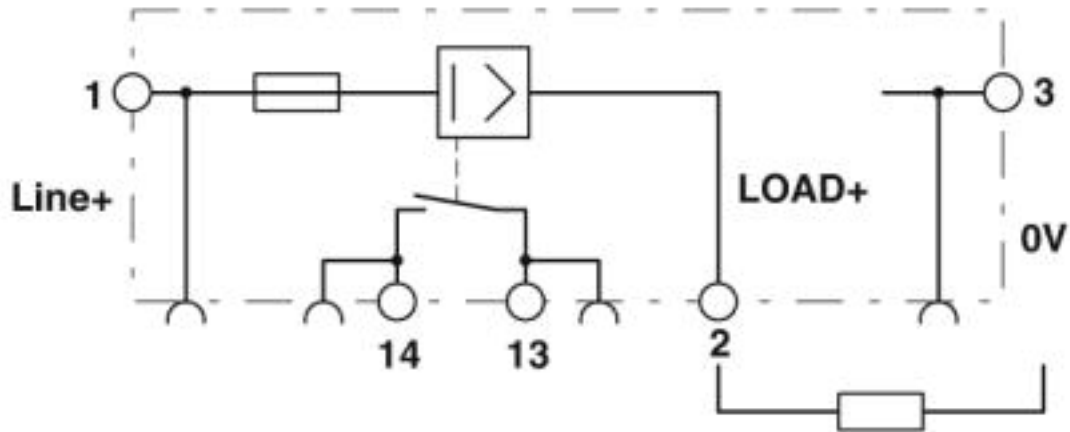

### Classifications

eCl@ss

eCl@ss 4.0	27141100
eCl@ss 4.1	27141100
eCl@ss 5.0	27141100
eCl@ss 5.1	27141100
eCl@ss 6.0	27141100
eCl@ss 7.0	27141116
eCl@ss 8.0	27141116
eCl@ss 9.0	27141116

ETIM

ETIM 2.0	EC000899
ETIM 3.0	EC000899
ETIM 4.0	EC000899
ETIM 5.0	EC000899
ETIM 6.0	EC000899
ETIM 7.0	EC000899

UNSPSC

UNSPSC 6.01	30211812
UNSPSC 7.0901	39121411
UNSPSC 11	39121411

# Electronic device circuit breaker - EC-E1 1A - 0903023

## Classifications

### UNSPSC

UNSPSC 12.01	39121411
UNSPSC 13.2	39121410

## Approvals

### Approvals

#### Approvals

DNV GL / UL Listed / UL Recognized / cUL Listed / EAC / EAC / cULus Listed

#### Ex Approvals

UL Recognized / CSA

### Approval details

DNV GL		<a href="https://approvalfinder.dnvgl.com/">https://approvalfinder.dnvgl.com/</a>	TAE00002HC
--------	--	---	------------

UL Listed		<a href="http://database.ul.com/cgi-bin/XYV/template/LISEXT/1FRAME/index.htm">http://database.ul.com/cgi-bin/XYV/template/LISEXT/1FRAME/index.htm</a>	FILE E 140324
-----------	--	---	---------------

UL Recognized		<a href="http://database.ul.com/cgi-bin/XYV/template/LISEXT/1FRAME/index.htm">http://database.ul.com/cgi-bin/XYV/template/LISEXT/1FRAME/index.htm</a>	FILE E 317172
---------------	--	---	---------------

cUL Listed		<a href="http://database.ul.com/cgi-bin/XYV/template/LISEXT/1FRAME/index.htm">http://database.ul.com/cgi-bin/XYV/template/LISEXT/1FRAME/index.htm</a>	FILE E 140324
------------	--	---	---------------

EAC			EAC-Zulassung
-----	--	--	---------------

## Electronic device circuit breaker - EC-E1 1A - 0903023

### Approvals

EAC		RU C- DE.A*30.B01546
-----	---	-------------------------

cULus Listed		
--------------	---	--

### Accessories

#### Accessories

#### Bridge

Continuous plug-in bridge - FBST 500-PLC BU - 2966692



Continuous plug-in bridge, length: 500 mm, color: blue

Continuous plug-in bridge - FBST 500-PLC RD - 2966786



Continuous plug-in bridge, length: 500 mm, color: red

Continuous plug-in bridge - FBST 500 TMC-N GY - 0901028



Continuous plug-in bridge, mounting type: Plug-in mounting, Color: gray

#### DIN rail

## Electronic device circuit breaker - EC-E1 1A - 0903023

### Accessories

DIN rail perforated - NS 35/ 7,5 PERF 2000MM - 0801733



DIN rail perforated, Standard profile, width: 35 mm, height: 7.5 mm, acc. to EN 60715, material: Steel, galvanized, passivated with a thick layer, length: 2000 mm, color: silver

---

DIN rail, unperforated - NS 35/ 7,5 CU UNPERF 2000MM - 0801762



DIN rail, unperforated, Standard profile, width: 35 mm, height: 7.5 mm, acc. to EN 60715, material: Copper, uncoated, length: 2000 mm, color: copper-colored

---

DIN rail, unperforated - NS 35/15 UNPERF 2000MM - 1201714



DIN rail, unperforated, Standard profile, width: 35 mm, height: 15 mm, similar to EN 60715, material: Steel, galvanized, passivated with a thick layer, length: 2000 mm, color: silver

---

DIN rail, unperforated - NS 35/15 CU UNPERF 2000MM - 1201895



DIN rail, unperforated, Standard profile, width: 35 mm, height: 15 mm, similar to EN 60715, material: Copper, uncoated, length: 2000 mm, color: copper-colored

---

DIN rail, unperforated - NS 35/15-2,3 UNPERF 2000MM - 1201798



DIN rail, unperforated, Standard profile 2.3 mm, width: 35 mm, height: 15 mm, acc. to EN 60715, material: Steel, galvanized, passivated with a thick layer, length: 2000 mm, color: silver

---

## Electronic device circuit breaker - EC-E1 1A - 0903023

### Accessories

DIN rail, unperforated - NS 35/15 AL UNPERF 2000MM - 1201756



DIN rail, unperforated, Standard profile, width: 35 mm, height: 15 mm, similar to EN 60715, material: Aluminum, uncoated, length: 2000 mm, color: silver

DIN rail perforated - NS 35/15 PERF 2000MM - 1201730



DIN rail perforated, Standard profile, width: 35 mm, height: 15 mm, similar to EN 60715, material: Steel, galvanized, passivated with a thick layer, length: 2000 mm, color: silver

### End block

End clamp - CLIPFIX 35-5 - 3022276



Quick mounting end clamp for NS 35/7,5 DIN rail or NS 35/15 DIN rail, with marking option, with parking option for FBS...5, FBS...6, KSS 5, KSS 6, width: 5.15 mm, color: gray

End clamp - E/UK 1 - 1201413



End clamps, for supporting the ends of double-level and three-level terminal blocks, width: 10 mm, color: gray

### Screwdriver tools

Screwdriver - SZS 0,6X3,5 - 1205053



Actuation tool, for ST terminal blocks, insulated, also suitable for use as a bladed screwdriver, size: 0.6 x 3.5 x 100 mm, 2-component grip, with non-slip grip

## Electronic device circuit breaker - EC-E1 1A - 0903023

### Accessories

---

#### Terminal marking

##### Marker for terminal blocks - UC-TMF 12 - 0819233



Marker for terminal blocks, Sheet, white, unlabeled, can be labeled with: BLUEMARK ID COLOR, BLUEMARK ID, BLUEMARK CLED, PLOTMARK, CMS-P1-PLOTTER, mounting type: snap into flat marker groove, for terminal block width: 12 mm, lettering field size: 11.45 x 5.1 mm, Number of individual labels: 40

---

##### Zack Marker strip, flat - ZBF 12:UNBEDRUCKT - 0809735



Zack Marker strip, flat, Strip, white, unlabeled, can be labeled with: PLOTMARK, CMS-P1-PLOTTER, mounting type: snap into flat marker groove, for terminal block width: 12 mm, lettering field size: 5.15 x 12.15 mm, Number of individual labels: 5